

STUDENTS: DALIN DU, JADE JWA, ELIZAVETA MANEVICH, KUAN-LIN CHEN

Exit Burrs

- Exit Burrs are deformations caused by the drills when drills exit onto the other side of the coupon
- They result in reduced fatigue life and electromagnetic issues that are caused when wires and connected to the inside of the planes.
- Current measuring process requires engineers to go inside of plane wings after assembly which is difficult and time consuming.

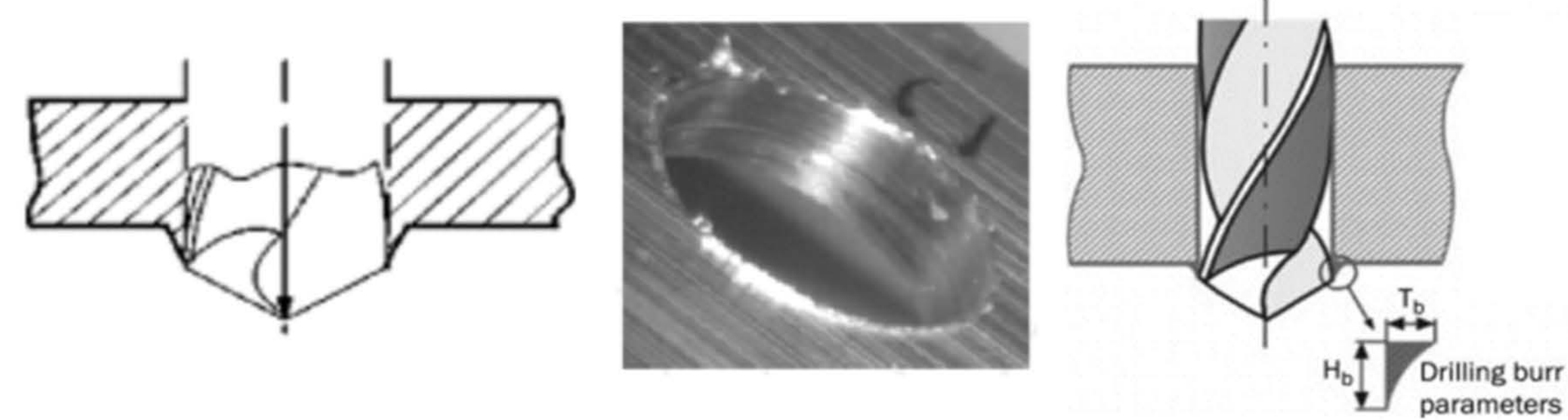

Design of the Probe

The design approach is faster and time saving than current measurement method. Basically it includes four main components

Tripod: The purpose of the tripod is to fix the distance from the conic mirror to the plate surface to get the pictures at the same distance because the thickness of the plate is varied.

Solenoid: The tripods can be controlled by the electromagnetic force induced by solenoid.

Convex mirror: The whole view of burr height can be pictured by the camera

Central rod: The central rod connected with the mirror and camera will not affect the vision on the rim of the circles, and it can also fix the distance from the camera to the mirror.

Measuring process:

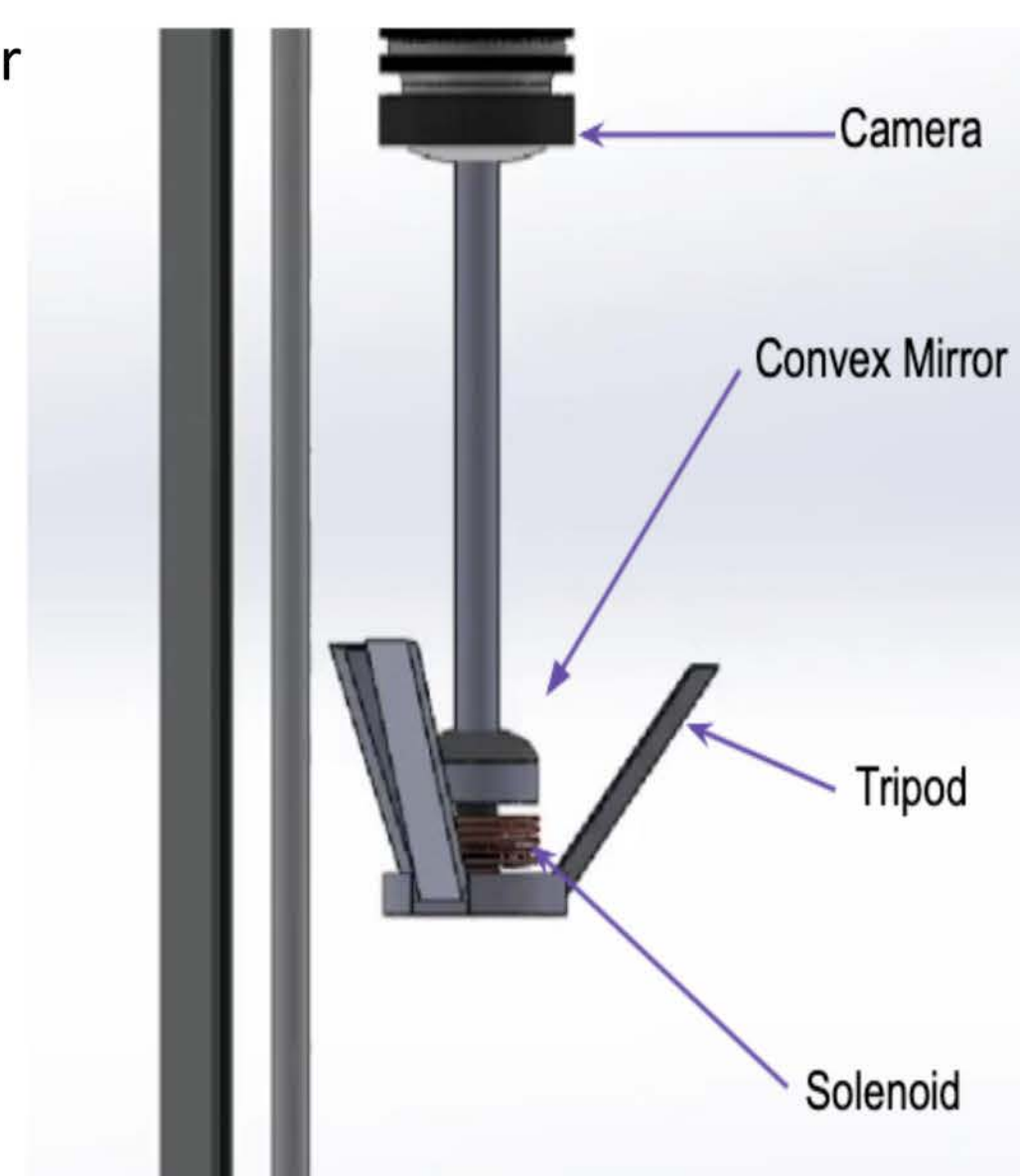
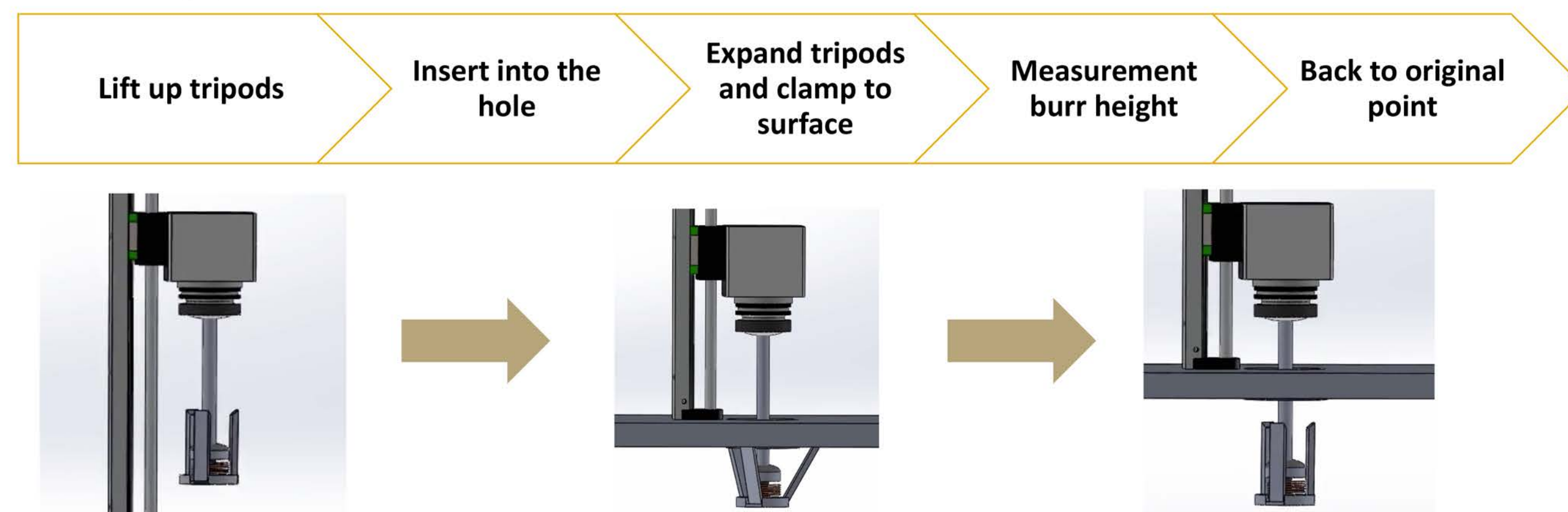

Technical Approach

Hough transfer

- Feature extraction technique used in digital image processing
- Detecting circles in imperfect images
- The circle candidates are produced by “voting” in the Hough parameter space
- Selecting local maxima in an accumulator matrix

Canny Edge Algorithm

- Created two masks – first with one that covers everything outside of circles of 0.05 inches, and the second covering everything inside the inner circle
- The masks’ purpose is to reduce noise in the images
- Performing canny edge detection in this status will give indices of every single edges which will then be used to calculate the distance from the center point.
- Then the value can be translated into the actual height using the mathematical model.

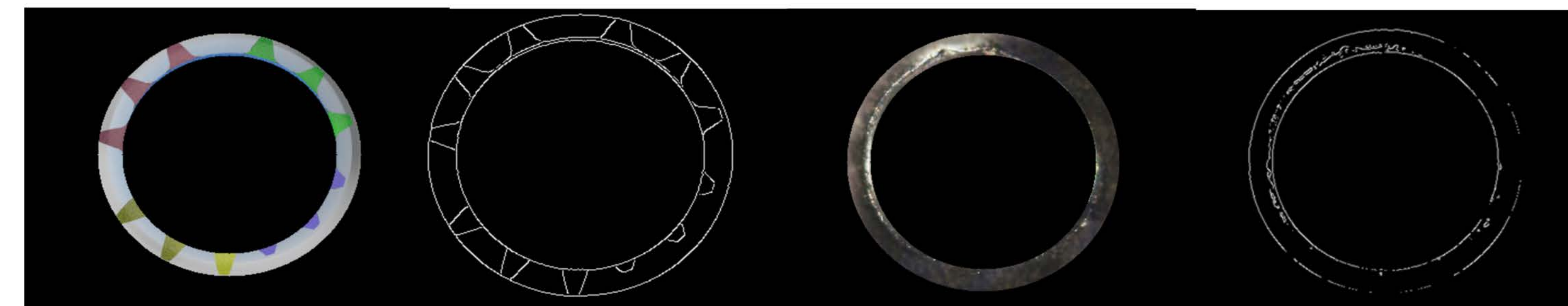

Keyshot

Keyshot is a simulation software used to render high quality images. It produces these images by utilizing ray tracing, which allows for a better reflection in the mirror model.

Process:

- Created models of the spherical mirror and coupons with known exit burr heights in Solidworks and then imported them into Keyshot.
- Adjusted the materials and position of the coupon and mirror to reflect the real-life set up.
- Captured images of the top view, just like the actual camera would, and ran the image through the hough algorithm which fit a circle to the highest points on the burr.
- Collected the radius of this circle and repeated the process for about 30 different heights.

After gathering an archive of all the hough circles and their corresponding burr heights, we formed a mathematical model that displays the correlation between the radius of the hough circle and the burr height.

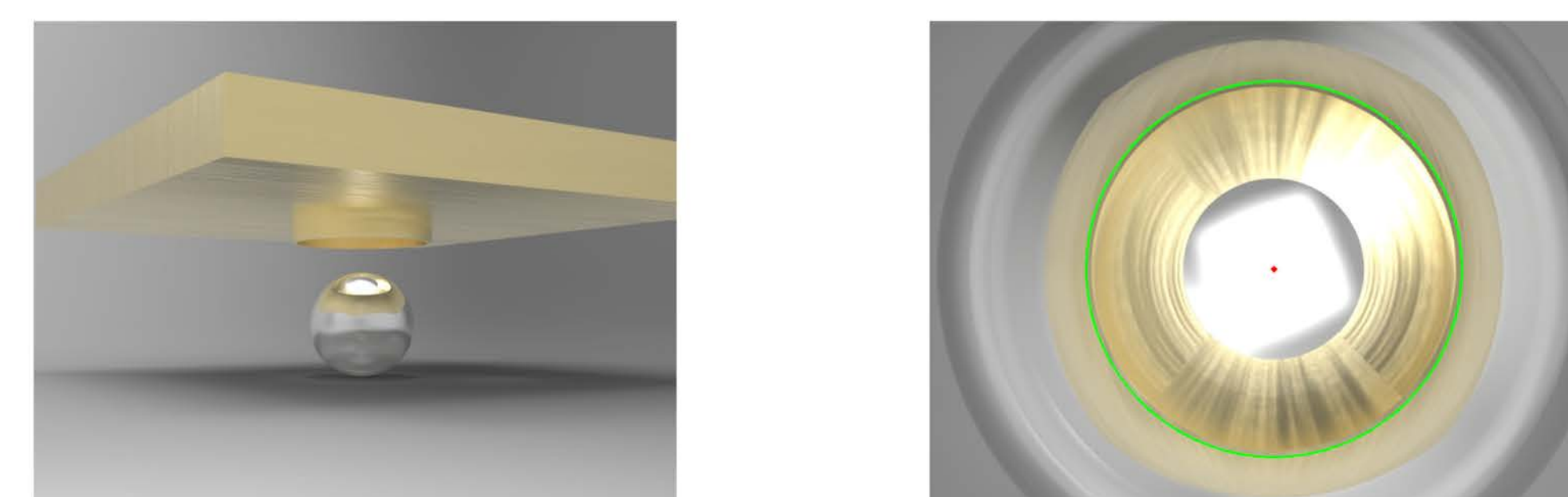

Mathematical Model

After collecting images and running the hough algorithm on about 30 known burr heights, we used MATLAB to create a mathematical model. The best fit for our data was a cubic function which shows the correlation between the radius of the hough circles and burr heights. By using this model, any burr height can be calculated by plugging the hough circle radius into the function which outputs the corresponding burr height.

Testing

In order to test the accuracy of the burr model, we took real burr images with a burr of a known height and went through the process. First, we ran the canny edge algorithm to detect the radius of the highest point on the burr and then plugged that radius into the mathematical function to find the height. Our margin of error was 7%, but this can be improved by taking higher quality pictures or by using more references to create a more accurate mathematical model.

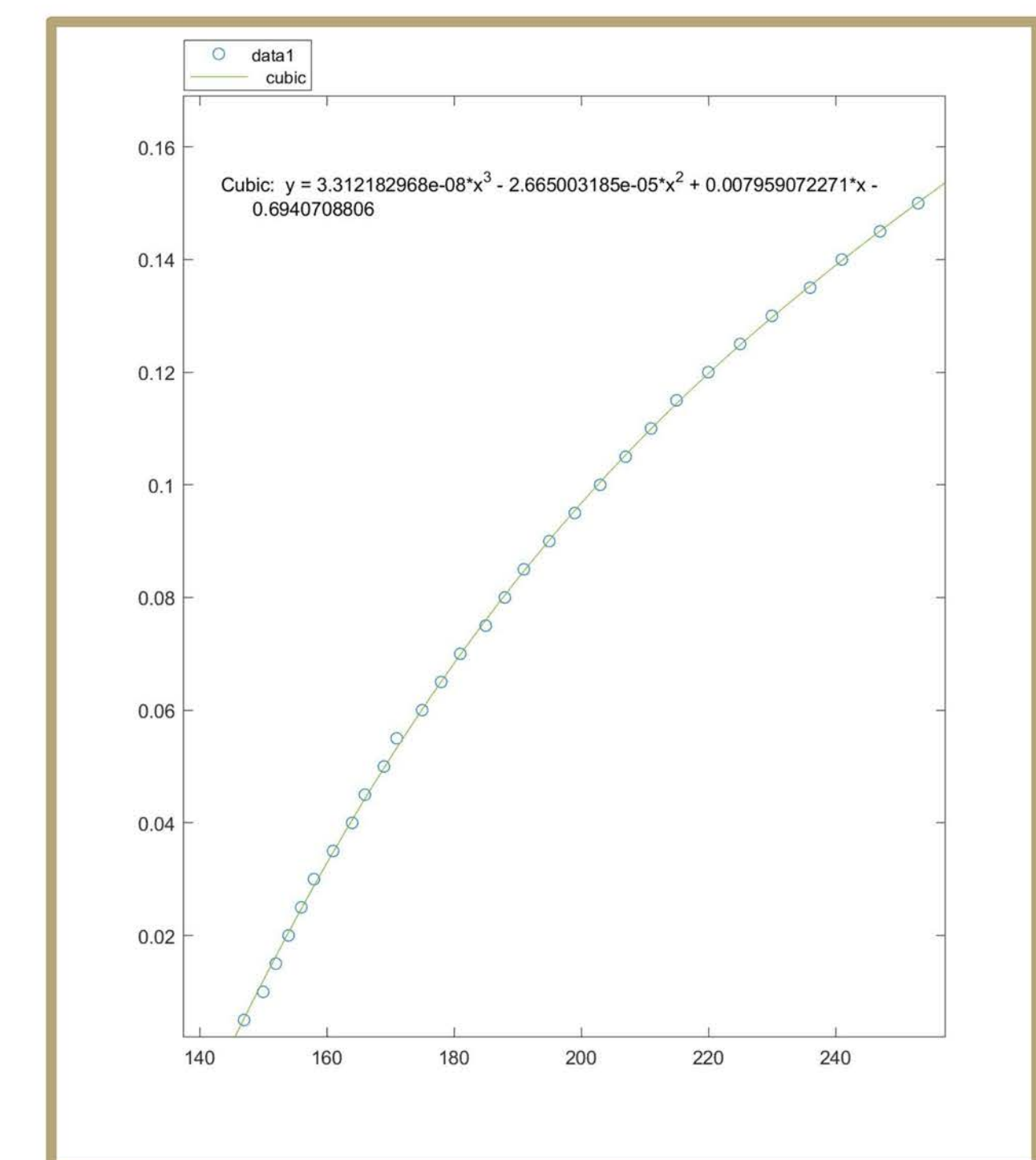

Future Work

Future improvement

Prototype completion

- Finish the prototype assembly once grant laboratory access.
- Testing real burr in laboratory setting
- Conduct safety assessment

Intensity Tracking Computer Vision Approach

- Align focal length with the highest point on the burr
- Move camera at very small increments and track the intensity of the pixels in the image
- Based on the intensity correlation, we can calculate height of the burr

Acknowledgements

Special thanks to

- Sam Pedigo, BARC Lab Associate Director ; Mitchell Johnson, Industry Mentor
- Payman Arabshahi, ENGINE Head Professor ; Brandon Yee, TA ; Niveditha Kalavakonda, TA
- Tai-Chang Chen, Faculty Mentor
- Ashis Banerjee, Advisor

for supporting the ENGINE capstone project and inspiring learning opportunity